



AVK RESILIENT SEAT GATE VALVE PN16

570/98

To AS 2638.2, reduced weight and environmentally friendly
 Stem sealing exchangeable under pressure
 Face to face dimension to AS 2638.2
 Flange and drilling to AS 4087 Figure B5 (AS 2129 Table D and raised face) or AS 2129 Table E and raised face

Use:

- For water, sewage and neutral liquid applications
- Valve designed for use up to 70°C
- Where applicable; for AS 4020 compliance, max temp = 40°C
 Note: Always observe pipe material recommended operating temperatures

Tests:

- Hydraulic test to AS 2638.2:
 - Seat: 17.6bar
 - Body: 24 bar
 - Operating torque test

Optional Extras:

- Stem cap (refer to series 570/90)



Quality
 ISO 9001
 SAI GLOBAL



Health & Safety
 AS 4801
 SAI GLOBAL



Environment
 ISO 14001
 SAI GLOBAL



Australian
 Standard
 AS2638.2:2011
 Lic. SMK02420
 SAI Global



WaterMark

DN80, 100, 150, 200

Expect... **AVK**

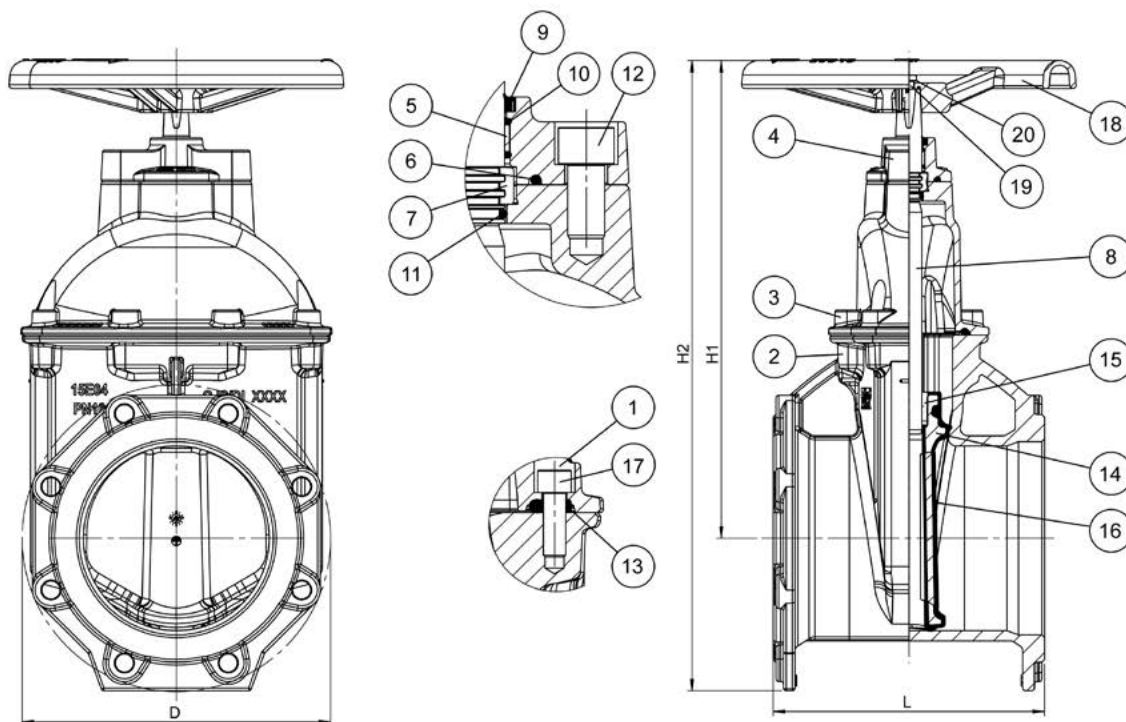

Component list

1. Hot melt seal		12. Bolt socket	Stainless Steel 316, fully, encapsulated with hot melt glue
2. Body	Ductile Iron, 500-7 to AS 1831	13. Bonnet gasket	EPDM rubber
3. Bonnet	Ductile Iron, 500-7 to AS 1831	14. Wedge	Ductile Iron, 500-7 to AS 1831
4. Gland flange	Ductile Iron, 500-7 to AS 1831	15. Wedge nut	Dezincification resistant brass, CZ 132 to AS 2345
5. Bushing	Polyamid	16. Wedge rubber	EPDM
6. O-ring	NBR	17. Bolt socket	Grade 8.8, fully encapsulated with hot melt glue
7. Thrust collar	Dezincification resistant brass, CZ 132 to AS 2345	18. Handwheel	Ductile Iron, 500-7 to AS 1831
8. Stem	Stainless Steel 431	19. Hex bolt	Stainless Steel 316
9. Wiper ring	NBR	20. Washer	
10. O-ring	NBR		
11. O-ring	NBR		

Components can be substituted with equivalent or higher class materials.

Reference nos. and dimensions - Flange drilling to AS 4087 Figure B5 (AS 2129 Table D)

AVK ref. nos. CC	AVK ref. nos. ACC	DN mm	L mm	H1 mm	H2 mm	D mm	Hole OD mm	Holes PCD	Bolt	Weight kilos	Handwheel OD mm
Refer 57/98 Datasheet		50*									
Refer 57/98 Datasheet		65*									
570-080-980540120	570-080-981540120	80	203	317	390	190	18.5	4	146	15	280
570-100-980540120	570-100-981540120	100	229	340	423	218	18.5	4	178	18	280
570-150-980540120	570-150-981540120	150	267	423	566	285	18.5	8	235	36	280
570-200-980540120	570-200-981540120	200	292	517	682	332	18.5	8	292	56	360
Refer 57/98 Datasheet		225									
Refer 57/98 Datasheet		250									
Refer 57/98 Datasheet		300									
Refer 57/48 Datasheet		375									
Refer 57/48 Datasheet		400									

* Not specified in AS 2638.2

Reference nos. and dimensions - Flange drilling to AS 2129 Table E

AVK ref. nos. CC	AVK ref. nos. ACC	DN mm	L mm	H1 mm	H2 mm	D mm	Hole OD mm	Holes PCD	Bolt	Weight kilos	Handwheel OD mm
Refer 57/98 Datasheet		50*									
Refer 57/98 Datasheet		65*									
570-080-980540120	570-080-981540120	80	203	317	390	190	18.5	4	146	15	280
Refer 57/98 Datasheet		100									
570-150-980640120	570-150-981640120	150	267	423	566	285	22.5	8	235	36	280
570-200-980640120	570-200-981640120	200	292	517	682	332	22.5	8	292	56	360
Refer 57/98 Datasheet		225									
Refer 57/98 Datasheet		250									
Refer 57/98 Datasheet		300									
Refer 57/48 Datasheet		375									
Refer 57/48 Datasheet		400									

* Not specified in AS 2638.2