

WANG TAPPING SADDLES

DN 40 - DN 450

FAST, PERMANENT TAPPING SOLUTION FOR BOTH RIGID AND FLEXIBLE PIPE TYPES



FEATURES

Saddle bodies are manufactured from either 316 stainless steel or Ductile Iron Fusion Bonded Epoxy coated (depending on saddle type) with 316 stainless steel fasteners

Nitrile rubber gaskets provide a potable water approved seal in all saddle types. Larger diameter Rigi-Tap saddles (DN 200 and larger) employ an EPDM back mat, insulating against galvanic corrosion

Fully passivated 316 stainless steel underscore the quality of the product

Dry film coating employed to minimise galling of the stainless steel fasteners

All sharp surfaces finished to avoid injury to the installer

Supplied with detailed installation instructions and pipe type compatibility information

Manufacturing facility certified to the ISO 9001 Quality Assured Standard

DESCRIPTION

WANG Tapping Saddles provide a quick and permanent means of tapping into both rigid and flexible pipe types

APPLICATION

Tapping saddles are ideal for service connections and provide an effective means of conducting an under pressure tapping

The saddle body supplies a strong reinforced aperture for the parent and offtake pipe

Note. This product is not suitable for gas application

TECHNICAL DATA

Size Range: DN 40 - DN 450
Depending on saddle type. See selection chart inside

Maximum Operating Pressure:
1600 kPa

Temperature Range: -10°C to 60°C

Relevant Standards:
AS/NZS 4793
Lic. No. SMK00278

WANG RIGI-TAP TAPPING SADDLES

APPLICATION

Nom. Pipe Size DN	Pipe Type Application	
	Rigid Non PVC	Flexible ALL PVC
40 - 450	✓	✗



STANDARD CLAMP DATA

Nom. Size mm	Offtake Size mm	Code Prefix	No. of Studs	Stud Size	No. of Saddle Segments	Saddle Width mm	OD Range mm
40 - 65	20, 25	KT1	1	M16	1	125	5
80 - 150	20, 25, 32, 40, 50	KT1	1	M16	1	125	10
200 - 450	20, 25, 32, 40, 50	KT4	4	M16	2	125	20

TYPICAL SPECIFYING SEQUENCE

Example	KT	1	-	168	T	020
KT = Tapping Saddle						
1 = Number of studs - only indicated on RIGI-TAP Saddles. 1 = 1 stud / 4 = 4 studs						
- = Delineator						
168 = Saddle size (start of the OD range)						
T = Offtake type (indicates female threaded BSP offtake)						
020 = Nominal offtake size. mm 020 = DN 20 / 025 = DN 25 / 032 = DN 32 / 040 = DN 40 / 050 = DN 50						

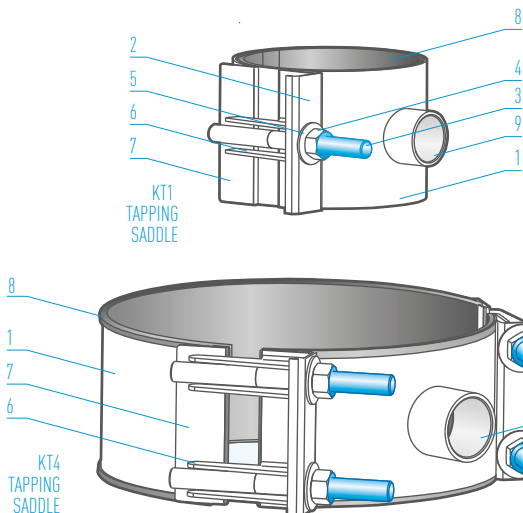

PARTS LIST

No	Description	Material / Standard
1	Skin	316 Stainless Steel / ASTM A240M
2	Locking Plate	316 Stainless Steel / ASTM A240M
3	Studs	316 Stainless Steel / Anti-galling compound coated ASTM A276
4	Nuts	316 Stainless Steel / Anti-galling compound coated ISO 4032, AS 1112.1
5	Washer	316 Stainless Steel / ISO 887
6	Lugs	316 Stainless Steel / ASTM A240M
7	Flat Bars	316 Stainless Steel / ASTM A240M
8	Sealing Gasket	Nitrile (NBR) compound / AS 1646 and AS/NZS 4020
9	BSP Offtake	316 Stainless Steel ASTM A312M, ISO 4144 or ANSI B16.3, AS 1722.1

WANG FLEXI-TAP TAPPING SADDLES

APPLICATION

Nom. Pipe Size DN	Pipe Type Application	
	Rigid Non PVC	Flexible All PVC
200 - 450	✗	✓



STANDARD CLAMP DATA

Nom. Size mm	Offtake Size mm	Code Prefix	No. of Studs	Stud Size	No. of Saddle Segments	Saddle Width mm	OD Range mm
200 - 450	20, 25, 32, 40, 50	KTFS	4	M16	2	125	0

TYPICAL SPECIFYING SEQUENCE

Example	KT	F	S	-	215	T	020
KT = Tapping Saddle							
F = Flexible pipe							
S = Stainless steel saddle body							
- = Delineator							
215 = Saddle size (fixed OD)							
T = Offtake type (indicates female threaded BSP offtake)							
020 = Nominal offtake size. mm 020 = DN 20 / 025 = DN 25 / 032 = DN 32 / 040 = DN 40 / 050 = DN 50							

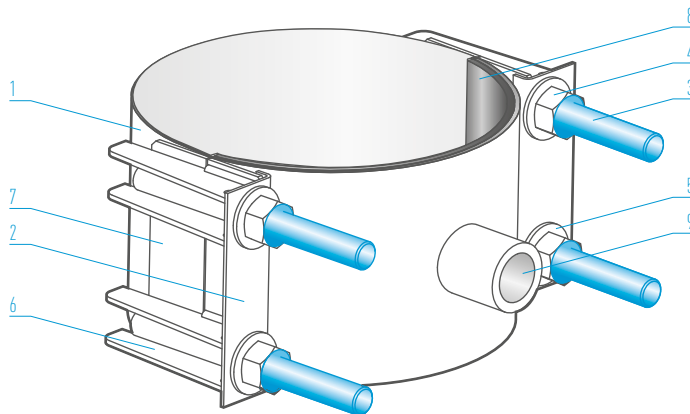

PARTS LIST

No.	Description	Material / Standard
1	Skin	316 Stainless Steel / ASTM A240M
2	Locking Plate	316 Stainless Steel / ASTM A240M
3	Studs	316 Stainless Steel / Anti-galling compound coated ASTM A276
4	Nuts	316 Stainless Steel / Anti-galling compound coated ISO 4032, AS 1112.1
5	Washer	316 Stainless Steel / ISO 887
6	Lugs	316 Stainless Steel / ASTM A240M
7	Flat Bars	316 Stainless Steel / ASTM A240M
8	Sealing Gasket	Nitrile (NBR) compound / AS 1646 and AS/NZS 4020
9	BSP Offtake	316 Stainless Steel ASTM A312M, ISO 4144 or ANSI B16.3, AS 1722.1

WANG VARI-TAP TAPPING SADDLES

APPLICATION

Nom. Pipe Size DN	Pipe Type Application	
	Rigid Non PVC	Flexible ALL PVC
100, 150	✓	✓

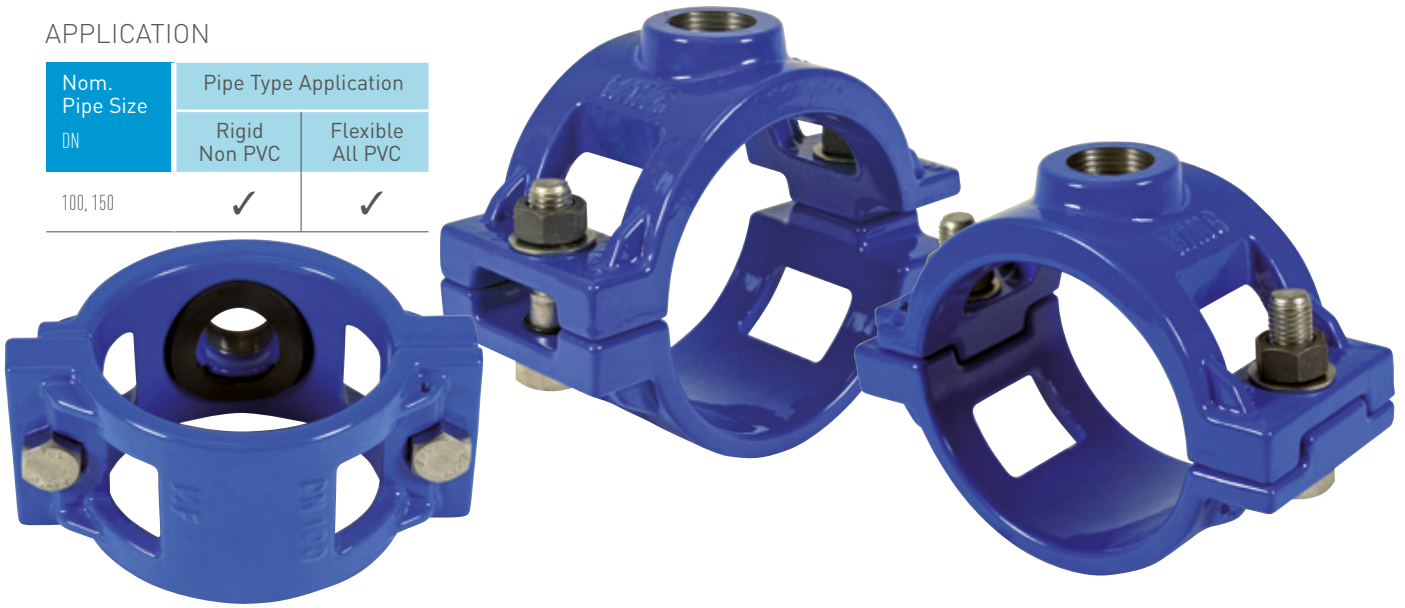

STANDARD CLAMP DATA

Nom. Size mm	Offtake Size mm	Code Prefix	No. of Studs	Stud Size	No. of Saddle Segments	Saddle Width mm	OD Range* mm
100	20, 25	KTFD	2	M16	2	90	113 - 122
150	20, 25	KTFD	2	M16	2	90	168 - 177

TYPICAL SPECIFYING SEQUENCE

Example	KT	F	D	-	122	T	020
KT = Tapping Saddle							
F = Flexible pipe							
D = DI-FBE coated saddle body							
- = Delineator							
122* = Saddle OD in flexible configuration							
T = Offtake type (indicates female threaded BSP offtake)							
* = Nominal offtake size. mm							
020 = DN 20 / 025 = DN 25							

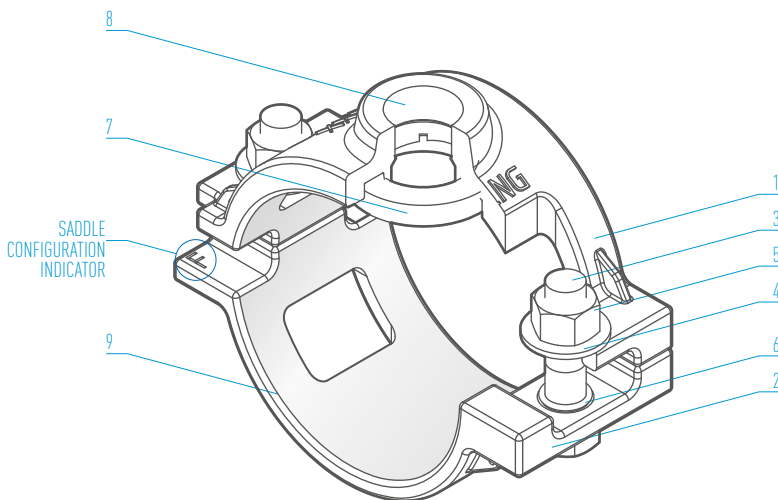

PARTS LIST

No.	Description	Material / Standard
1	Top Segment	Ductile Iron / AS1831
2	Bottom Segment	Ductile Iron / AS1831
3	Bolt	M16 x 65mm Hex Head 316 Stainless Steel / AS1110
4	Washer - M16	316 Stainless Steel / ISO 7089
5	Nut	316 Stainless Steel Anti-galling compound coated ISO 4032, AS 1112.1
6	Retaining O-Ring	Nitrile (NBR) Rubber
7	Ring Seal Gasket	Nitrile (NBR) Rubber / AS1646 & AS4020
8	BSP thread - RP	ISO 7.1
9	Coating	Fusion Bonded Epoxy / AS4158

WANG TAPPING SADDLES - PN 16 OPERATING PRESSURE



RIGID AND FLEXIBLE PRESSURE PIPE

Nom. Pipe Size	RIGID PIPE						FLEXIBLE PIPE			
	DICL	Steel	CICL		AC		GRP*2	RC	PVC	HDPE
DN	AS/NZS 2281	MSCL AS 1579	B AS 1724	C AS 2544	AB AS 1711	CD AS 1711	Series 1 - B5 AS 3571	AS 4058	Series 2 (U) AS/NZS 1477 (M) AS/NZS 4765 (O) AS/NZS 4441	AS/NZS 4130
40		KT1-04710??					KT1-04710??			
50		KT1-05910??					KT1-05910??			
65		KT1-07510??					64mm			
80		KT1-08810??					KT1-10110??			
100		KT1-11410??					KT1-11410??			
125		KT1-14010??					KT1-14010??			
150		KT1-16810??					KT1-17510??			
175		KT1-17710??					KT1-17710??			
200		KT4-21510??					KT4-21510??			
225		KT4-25010??					KT4-25010??			
250		KT4-27010??					KT4-27010??			
300		KT4-31510??					KT4-31510??			
350		KT4-35510??					KT4-35510??			
375		KT4-39010??					KT4-39010??			
400		KT4-44010??					KT4-44010??			
450		KT4-49010??					KT4-49010??			

Select missing offtake size as shown in the typical specifying sequence

S Steel Rigi-lap Saddle option
Cast Vari-lap Saddle option
Pipe 00

*** Contact Pentair Water Solutions for further information and availability of this product.
*1 Min. required pipe rating for saddle application: PN9 *2 Min. required pipe rating for saddle application: SM10.000

WANG CLAMPS & COUPLINGS

WANG is one of the leading manufacturers and suppliers of Grade 316 Stainless Steel Repair and Tapped Clamps as well as Couplings for reticulated water, sewerage and gas mains including industrial piping systems.

As part of the Pentair Water Solutions business, WANG products have become synonymous with quality and reliability. Our product range is widely utilised and relied upon by Water Authorities and Councils throughout Australia in the installation and maintenance of their supply mains and reticulation network.



Wang Components products can be sourced through the Pentair Water Solutions national sales and service network of customer centres.

Pentair Water Solutions is a specialist in integrated solutions for all your water and wastewater pipeline system requirements.

KWIK CLAMPS

A full circle repair clamp for small bore galvanised steel, copper and PVC pipe. DN 15 - DN 50



REPAIR CLAMPS

A fast, permanent and economical repair solution for most pipe types and sizes. DN 50 - DN 1200



TAPPED CLAMPS

A reliable means of tapping into old, unstable or damaged pipe. DN 50 - DN 1200



HDPE CLAMPS

Provide fast, expedient on-site repair and tapping solutions for HDPE pipe. DN 40 - DN 600

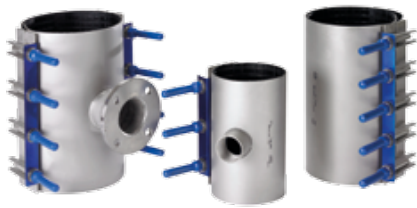

FLANGED OFFTAKE CLAMPS

A cost effective means of achieving a 'T' connection or under pressure tapping. DN 100 - DN 900



SEWER OB JUNCTION CLAMPS

A quick method of installing a new property service connection on a sewer main. DN 100 - DN 450



VARI GIB COUPLINGS

Non-restrained mechanical couplings for connecting pipes with equal or unequal diameters. DN 40 - DN 1200



HIGH PRESSURE COUPLINGS

Provides a mechanical joint between similar or dissimilar pipes in high pressure environments. DN 150 - DN 2000



SOCKET JOINT LEAK CLAMPS

Provide a permanent and economical seal over a leaking socket-spigot joint. DN 80 - DN 1200

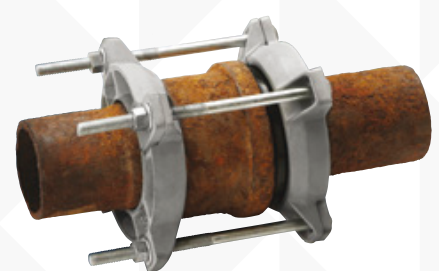

PENTAIR WATER SOLUTIONS

LEVEL 3, 9 GEORGE STREET, PARRAMATTA, NEW SOUTH WALES 2150 / WWW.PENTAIR.COM/WATERSOLUTIONS
PHONE 02 9794 3400 AUSTRALIA / 09 921 7230 NEW ZEALAND

All Pentair trademarks and logos are owned by Pentair Ltd. All other brand or product names are trademarks or registered marks of their respective owners. Because we are continuously improving our products and services, Pentair reserves the right to change specifications without prior notice.
PNR_TS0214© 2013 Pentair Ltd. All Rights Reserved.